

Eclipse Programmable Rotary Actuator

Series PRA6

Version 1

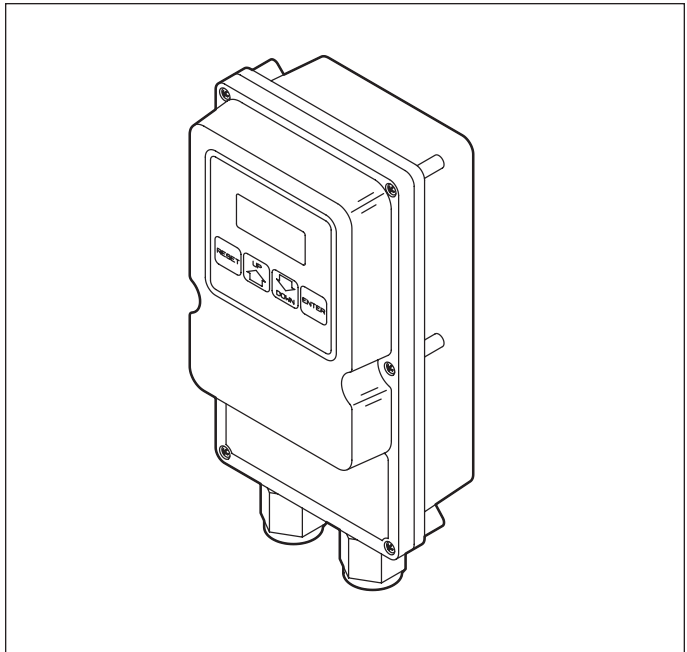

COPYRIGHT

Copyright 2006 by Eclipse, Inc. All rights reserved worldwide. This publication is protected by federal regulation and shall not be copied, distributed, transmitted, transcribed or translated into any human or computer language, in any form or by any means, to any third parties, without the express written consent of Eclipse, Inc.

DISCLAIMER NOTICE

In accordance with the manufacturer's policy of continual product improvement, the product presented in this brochure is subject to change without notice or obligation.

The material in this manual is believed adequate for the intended use of the product. If the product is used for purposes other than those specified herein, confirmation of validity and suitability must be obtained. Eclipse, Inc. warrants that the product itself does not infringe upon any United States patents. No further warranty is expressed or implied.

We have made every effort to make this manual as accurate and complete as possible. Should you find errors or omissions, please bring them to our attention so that we may correct them. In this way we hope to improve our product documentation for the benefit of our customers. Please send your corrections and comments to our Marketing Communications Manager.

LIABILITY AND WARRANTY

It must be understood that Eclipse's liability for its products, whether due to breach of warranty, negligence, strict liability, or otherwise, is limited to the furnishing of rotary actuator replacement parts and Eclipse will not be liable for any other injury, loss, damage or expenses, whether direct or consequential, including but not limited to loss of use, income of, or damage to material arising in connection with the sale, installation, use of, inability to use or the repair or replacement of our products.



About this manual

AUDIENCE

This manual has been written for the people who will install the product and the technicians who work on it. They are expected to have previous experience with this kind of equipment.

SCOPE

This manual contains essential information for the proper installation and operation of an Eclipse Programmable Rotary Actuator.

ACTUATOR PUBLICATIONS

Instruction Manual No. 904

- This publication.

Data Sheet No. 904

- Lists actuator information including dimensions.

Price Sheet No. 904

- Used to order actuators.

IMPORTANT NOTICES

- Read this manual carefully. Make sure that you understand the structure and contents of this manual.
- Obey all the safety instructions.
- Do not deviate from any instructions or application limits in this manual without written consent from Eclipse, Inc.
- If you do not understand any part of the information in this manual, do not continue. Contact your Eclipse sales office or Eclipse, Inc.

DOCUMENT CONVENTIONS

There are several special symbols in this document. You must know their meaning and importance.

The explanation of these symbols follows. Please read it thoroughly.



Warning:

Indicates hazards or unsafe practices which could result in severe personal injury or damage.

Act with great care and follow the instructions.



Caution:

Indicates hazards or unsafe practices which could result in damage to the machine or minor personal injury.

Act carefully.



Note:

Indicates an important part of the text.

Read the text thoroughly.



Table of Contents

	About this manual	3
	Audience	3
	Scope	3
	Actuator Publications.....	3
	Important Notices	3
	Document Conventions	4
	Table of Contents	5
1	Introduction	7
	Product Description.....	7
2	Installation	8
	Introduction	8
	Handling and Storage	8
	Approval of Components.....	9
	Electrical wiring	9
	Where to get the standards	9
	Checklist Before Installation.....	9
	A Note on Safety.....	10
	Actuator Mounting	11
	Mount Actuator to Butterfly Valve	12
	Actuator Wiring	15
	Power supply.....	16
	Auxiliary contacts	16
	Low fire wiring	16
	High fire wiring.....	17
	Control signal wiring.....	17
	Disable settings wiring.....	17

3	Parameter Selection	21
	Introduction	21
	Low Fire Stop (LF).....	21
	High Fire Stop (HF)	22
	Control Signal Loss (LO).....	22
	Low Fire Contact Release (LL).....	23
	Low Fire Contact Sense (LS).....	23
	High Fire Contact Sense (HS).....	25
	High Fire Contact Release (HH)	26
	Manual Position Select	26
	Signal Input Select	27
	Auxiliary Contact Select–Normally Closed.....	27
	Auxiliary Contact Select–Normally Open.....	27
	Clockwise Rotation Select.....	28
	Counterclockwise Rotation Select	28
	Examine Setpoints.....	28
	Default Setpoints.....	29
	Stalled Motor	29
4	Specifications	30
	Dimensions.....	31
	Keypad orientations.....	32
5	Maintenance & Troubleshooting	33
	Introduction	33
	Maintenance	33
	Monthly Checklist.....	33
	Yearly Checklist.....	33
	Troubleshooting.....	34
	Appendix	35
	Table 1: Actuator Parameter Record	35
	Table 2: Model Number Configuration	35

Introduction

1

PRODUCT DESCRIPTION

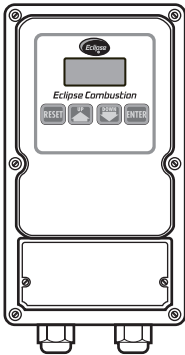

Upright (Standard) Orientation

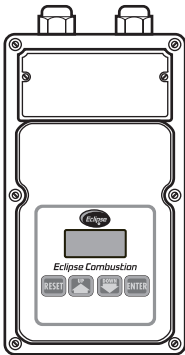

Inverted Orientation

The Eclipse Programmable Rotary Actuator is a keypad-programmable, direct-coupled modulating motor for use in burner and valve control systems. It is typically used with an electronic control to regulate a process temperature. The drive shaft of the actuator connects to a butterfly valve stem, which rotates 90 degrees from minimum to maximum position.

Actuator features include: solid state electronics; LED display with membrane keys; 4-20mA, 0-10Vdc and switch inputs for positioning; and two auxiliary contacts for position feedback.

The display keypad provides indication of position and direction of travel, and allows local manual positioning control. It also provides access to set the following parameters: minimum and maximum travel positions; actuation position for the auxiliary contacts; and direction of rotation.

The display keypad can be ordered in four positions: *upright* (standard) for vertical mounting with the wiring connections at the bottom; 90 degrees (RH) for horizontal mounting with the wiring connections to the right; 270 degrees (LH) for horizontal mounting with the wiring connections to the left; or *inverted* for mounting with the wiring connections at the top. (See page 32 for additional keypad orientation illustrations.) The keypad orientation cannot be changed in the field.



Note:

These instructions apply to heating applications where a maximum output from the temperature controller drives a butterfly valve up to its maximum flow position.

Installation

2

INTRODUCTION

In this section you will find the information and instructions that you need to install the actuator.



Caution:

Installation and maintenance must conform with the National Electrical Code and all other national and local codes and authorities having jurisdiction. The actuator must be installed by a qualified, licensed technician.

HANDLING AND STORAGE

Handling

1. Make sure that the area is clean.
2. Protect the actuator from the weather, damage, dirt and moisture.
3. Protect the actuator from excessive temperatures and humidity.
4. Take care not to hit or drop the actuator.

Storage

1. Make sure that the actuator is clean and in good condition.
2. After you have made sure that everything is present and in good condition, keep the actuator in the original package as long as possible.
3. Store the actuator in a cool, clean, dry room.

APPROVAL OF COMPONENTS

Electrical Wiring

All of the electrical wiring must comply with one of the following standards:

- NFPA Standards 70
- EN60204-1
- the electrical wiring must be acceptable to the local authority having jurisdiction.

Where to get the standards

The NFPA Standards are available from:

National Fire Protection Agency
Batterymarch Park
Quincy, MA 02269

Information on the EN standards, and where to get the standards is available from:

European Committee for Electrotechnical Standardization
4, Galerie Ravenstein
B-1000 Brussels, Belgium

CHECKLIST BEFORE INSTALLATION

Access

Make sure that you install the actuator in such a way that you have easy access to it for inspection and maintenance.

Environment

Make sure that the local environment matches the original operating specifications. Check the following items:

- voltage, frequency and stability of the electrical power
- humidity, altitude and temperature of air
- presence of damaging corrosive gases in the air.

A Note on Safety

The Eclipse Programmable Rotary Actuator must be used with an approved listed combustion control system consisting of a flame safeguard and safety shut-off valves. The diagrams below illustrate the general arrangement of the typical control schemes. These diagrams do not show all of the devices that may be required for a complete control system and are not meant to be used for construction.

Fixed Air Burner

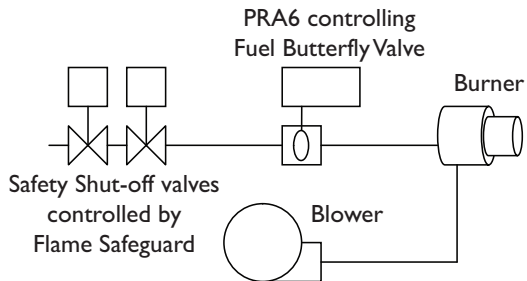

Ratio Burner

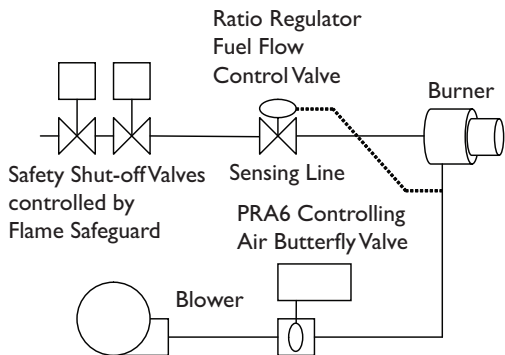

Caution:

Use of this product in the European community shall only be deployed in a manner that meets the applicable EC directives and laws.

ACTUATOR MOUNTING

Depending on your application, please keep the following in mind when mounting the actuator:

- The actuator housing has three mounting holes, as shown in Figure 1. The holes are threaded and use M6 metric screws.
- Mounting this actuator depends on the application; See Data 904 and contact Eclipse, Inc. for available mounting kits.
- When mounting the actuator, be certain that the actuator's drive shaft is properly aligned with the other shaft to which it will be coupled to avoid undue lateral stress.
- The actuator's drive shaft has a 3mm through hole for a coupler, as shown in Figure 1.
- Provide support for the weight of conduit or cables into the actuator.

Figure 1 Coupler & Mounting Holes Location

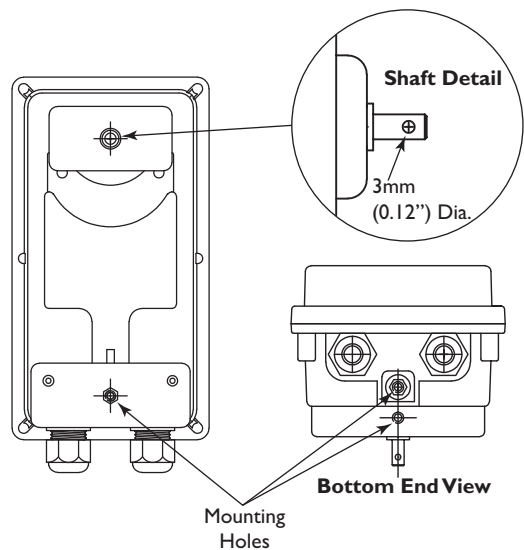

MOUNT ACTUATOR TO BUTTERFLY VALVE



Caution:

Electrical fittings are factory installed to maintain seal and must not be altered. Use only factory supplied fittings assembled as shown on Data 904.



Caution:

Prevent water from condensation flowing into the actuator housing through the wiring conduits. Keep conduits oriented such that gravity will cause water to flow away from the actuator or provide a watertight seal in the conduit near the actuator.



Warning

Local regulations may require guards and/or warnings when connecting the actuator to a component with linkage that could cause finger pinching. The actuator stall torque is at least 3.9 n-m (35 lb-in).



Warning

Do not attempt to mechanically force the PRA6 shaft to rotate

- I. Determine if the butterfly valve (BV) has unrestricted full rotation or if it has physical stops that limit rotation to a specific angle. Also determine the minimum position, rotation direction to open, and maximum open position for the BV. The Programmable Rotary Actuator (PRA) is shipped in its minimum position, clockwise to open, and the part number shows whether the stroke has been factory set to either 90 degrees or 75 degrees (see Table 2 of the Appendix). These settings can be changed through the keypad. Compare the BV requirements to the PRA.

Butterfly Valve

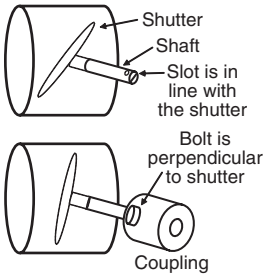

Note:

The butterfly valve rotation direction is viewed from the shaft end connected to the actuator, the same view as facing the actuator's keypad. The slot at the end of the butterfly valve shaft is parallel to the shutter. When the shaft is rotated to align the slot to the pipe direction, the valve is at maximum flow. Eclipse BVs with the beveled shutter option have a 75-degree stroke. The minimum positions of these valves physically stop at about a 15-degree angle when the butterfly shaft is turned fully counter-clockwise. Therefore the PRA must have its low position set to about 15 to prevent trying to rotate against the physical stop. Final fine-tuning adjustments to the minimum position can be made after mounting the PRA to the BV.

2. If the stroke or rotation comparison does not match or if you suspect the PRA has been set differently from the part number, then provide temporary power to the PRA before mounting. Refer to the "Power Supply" heading on page 16. Then refer to Section 3 ("Parameter Selection," page 21) and adjust the settings as follows:
 - a. Refer to "Clockwise or Counterclockwise Rotation Select" to set the rotation direction to match the BV.
 - b. Refer to "Low Fire Stop (LF)" to set the minimum position. Also reference the note for "Control Signal Loss (LO)".
 - c. Refer to "High Fire Stop (HF)" to set the maximum position.
 - d. Check your settings by putting the PRA in the manual mode (see Section 3, "Parameter Selection" and "Manual Position Select"). Drive the PRA up to the full open position and note the display and shaft. Then drive back down to the full closed position and note the display and shaft.

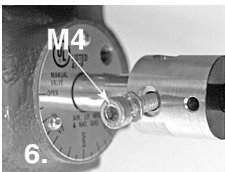
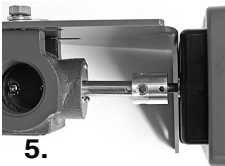
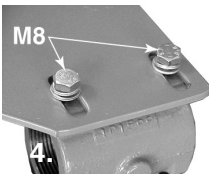
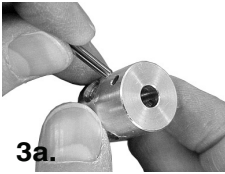

3. Install the coupling to the PRA shaft. For the standard solid coupling with a 3mm slotted spring pin:
 - a. Insert the spring pin partially into the coupling. Insertion may be easier by first squeezing the tip slightly with pliers.
 - b. Slide the coupling onto the PRA shaft and align the spring pin hole in the coupling with the through hole in the shaft. A view from the opposite side open hole of the coupling will assist alignment.
 - c. Use slip-lock pliers to press the spring pin through the coupling and shaft. Make sure the actuator body is supported and be careful not to apply excessive stress on the shaft.
4. Loosely attach the mounting bracket to the BV. The Eclipse mounting kits include M8 bolts, flat washers, and lock washers for this purpose. Do not tighten at this time to allow alignment in the next steps.
5. Rotate the BV to its minimum position to match the position of the PRA. Slide the PRA with coupling onto the BV shaft and align to the bracket.
6. Insert the M4 bolt and lock washer through the coupling hole and thread about 4 turns into the BV shaft.
7. Adjust the bracket along its slots to bring the bracket mounting surface up to the PRA. Also check and keep the alignment of the BV and PRA shafts. Attach the M6 bolt and washer through the bracket into the mounting hole of the PRA (Figure 1), finger tight only. Also finger tighten the M8 bolts holding the bracket to the BV.
8. Remove the M4 bolt from the coupling. Grab the BV shaft with your fingers and see if the shaft can be turned within the coupling. If the shaft is very difficult to turn,



8.

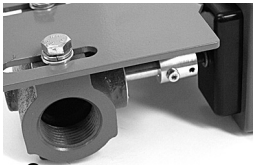

9.

then the bracket must be re-aligned as follows:

- a. Partially reinsert the M4 bolt through the coupling.
 - b. Loosen the M6 and M8 bolts as required to make small adjustments to the bracket alignment until the BV shaft can be turned by finger within the coupling when the M4 bolt is removed.
 - c. Finger-tighten the bolts and repeat step 8.
9. Tighten the M8 bolts to 5 Nm (45 lb-in) and check if the alignment has shifted as in step 8. Tighten the M6 bolt to 2 Nm (19 lb-in). Insert and tighten the M4 bolt to 1 Nm (9 lb-in).
 10. Make the electrical connections either temporary or as required by the application and apply power. Verify for proper and smooth motion over the full stroke range, see step 2-d. Correct any abnormalities before placing the equipment into operation. Place the PRA into the correct operating mode (manual or automatic) as required by the application, Section 3 “Parameter Selection” and “Manual Position Select” or “Automatic Signal Input Select.”

ACTUATOR WIRING

Access is through the two electrical connectors at the end of the actuator. Remove the front coverplate to access the terminal strips, as shown in Figure 2.



Warning:

Risk of electric shock. Removal of the cover plate allows access to conductors carrying hazardous voltages.

Once the front coverplate is removed, the terminal strip on the left side (P2) is used for the power supply, and low and high fire auxiliary contacts. The terminal strip on the right side (P1) is used for the control signal inputs (4-20mA, 0-10V, etc.).

To install a wire into a terminal, first be sure the terminal is full open. Strip the wire insulation back 1/4" (6mm), and insert the wire. Hold the wire in place while tightening the terminal screw. Inspect the wire for loose strands and gently pull it to ensure a secure connection. Use only one wire per terminal.

Figure 3 on page 18 shows the wiring diagram for the actuator, while Figure 4 on page 19 shows a typical application.



Warning:

After wiring, inspect the seal and install the cover carefully. Make sure cover is seated properly to seal out water.

Power Supply

Connect the ground wire to P2-G, the neutral conductor to P2-1, and the "hot" or line voltage conductor to P2-2. Provide proper circuit protection (fuse or circuit breaker).

Auxiliary Contacts

The internal contacts are isolated and voltage-free. Take care not to exceed the contact ratings listed in the specifications table on page 30. These contacts can be used for position detection. Connect an external supply to the common terminals, P2-3 and P2-5. Connect the external low position load to P2-6, and the external high position load to P2-4.

Low Fire Wiring

A switch or voltage-free contact can be wired between P1-5 (Low Fire) and P1-1 (COM) to move the actuator to the low fire position.

Figure 2 Coverplate & Terminal Connections

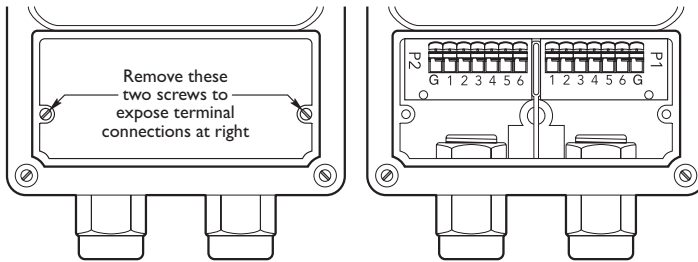

High Fire Wiring

A switch or voltage-free contact can be wired between PI-4 (High FIRE) and PI-1 (COM) to move the actuator to the high fire position.



Note:

These digital signals override the 4-20mA and 0-10Vdc analog positioning signals.

Control Signal Wiring

Connect a 4-20mA signal positive (+) to PI-2 and negative (-) to PI-1 (COM). Or alternately connect a 0-10 Vdc signal positive (+) to PI-3 and negative (-) to PI-1 (COM). If both signals are connected, the greater value signal will determine the actuator's position.

Disable Settings Wiring

After setting the parameters according to Section 3, connect PI-6 (LC) to PI-1 (COM) to prevent inadvertent parameter changes through the keypad. With this jumper installed, pressing the ENTER key will display "LC" and not allow parameter changes.

Figure 3 Wiring Diagram for Actuator

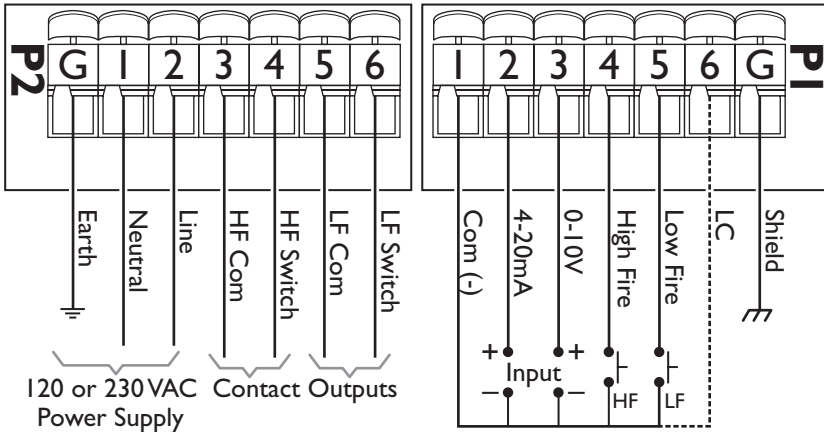

Note:

1. Separate low voltage signal wiring from high voltage signal wiring.
2. Control circuit wires must:
 - a) meet 90°C (194°F) specification minimum;
 - b) recommended range from 22 to 16 AWG (.5 to 1.5mm²), and
 - c) be in accordance with all applicable codes.
3. Insert only one wire per terminal.
4. Provide power supply circuit protection.
5. P2-G and P1-G are internally connected

Figure 4 Typical Application



Note:

The following diagram is an example of how to use the actuator's various inputs and outputs. Some devices shown may be omitted or changed, depending on your application.

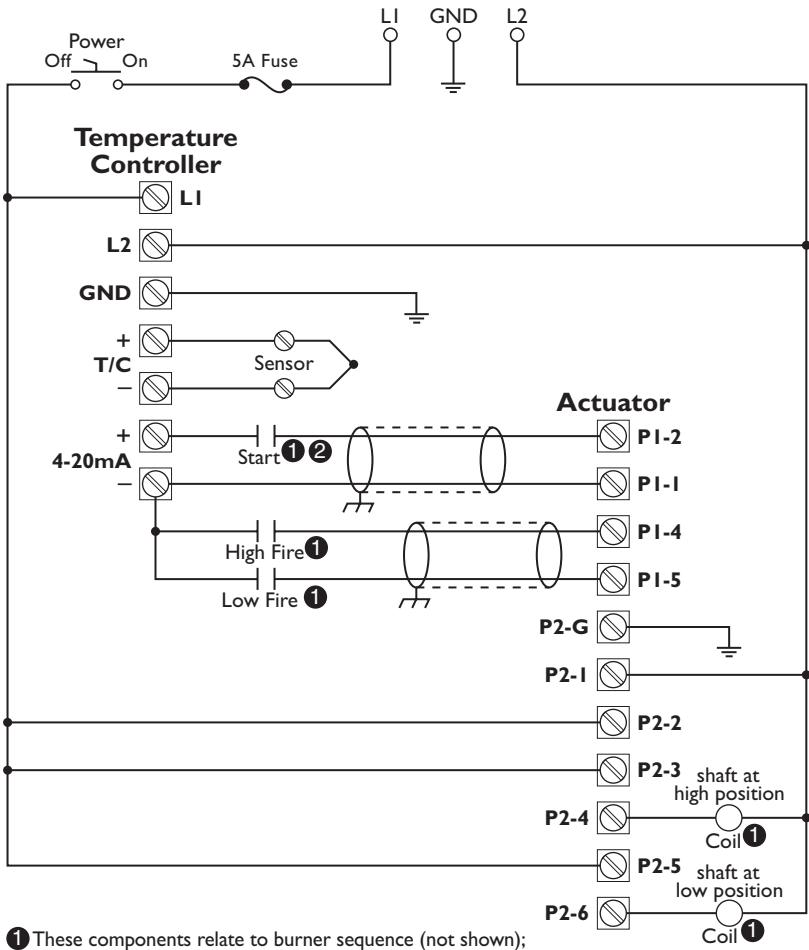

- ❶ These components relate to burner sequence (not shown);
- ❷ See "Control Signal Loss (LO)" on page 22.

CHECKLIST AFTER INSTALLATION

1. Confirm the alignment and tightness of all mechanical connections.
2. Inspect the terminal wiring for stray wire strands that might cause a short circuit. Check that the wires are properly inserted into the terminals and are not loose. Reinstall the terminal cover.
3. Apply power and verify that the stroke motion is smooth over its entire range. Refer to Section 3, "Parameter Selections," for any adjustments.
4. Record the parameter settings for future reference in Table I, Actuator Parameter Configuration Record, on page 35.

Parameter Selection 3

INTRODUCTION

LOW FIRE STOP (LF)

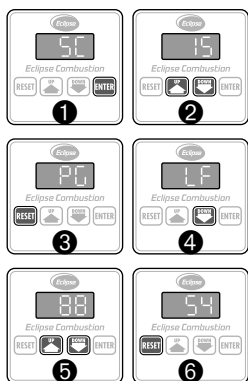

In this section you will find the information about the actuators various selectable parameters, and how they can be programmed through the keypad.

This parameter sets the minimum shaft travel position:

1. Press the ENTER key; the message “SC” will appear on the display.
2. Press either the UP or DOWN key until the number “15” appears on the display.
3. Press the RESET key; the message “PG” will appear on the display.
4. Press the DOWN key; the message “LF” will appear on the display.
5. Press either the UP or DOWN key until your desired number (the desired degree of shaft rotation) appears on the display.
6. Press the RESET key to complete the sequence.

HIGH FIRE STOP (HF)

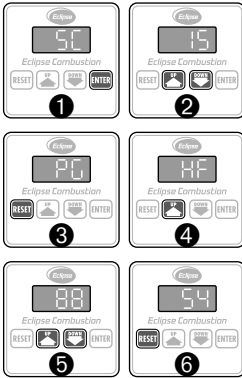

CONTROL SIGNAL LOSS (LO)

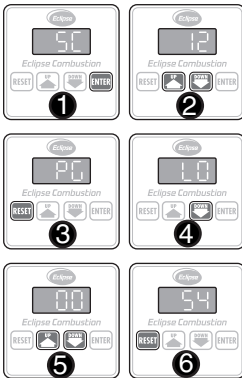

This parameter sets the highest shaft travel position:

1. Press the ENTER key; the message “SC” will appear on the display.
2. Press either the UP or DOWN key until the number “15” appears on the display.
3. Press the RESET key; the message “PG” will appear on the display.
4. Press the UP key; the message “HF” will appear on the display.
5. Press either the UP or DOWN key until your desired number (the desired degree of shaft rotation) appears on the display.
6. Press the RESET key to complete the sequence.

This parameter sets the position when the analog control signal is zero. It can be used to set a control valve at some intermediate position above LF for burner start-up (see Figure 4 on page 19):



Note:

Set LO to the same value as LF if you want the actuator to drive to the Low Fire Stop position (LF) when the control signal is zero.

1. Press the ENTER key; the message “SC” will appear on the display.
2. Press either the UP or DOWN key until the number “12” appears on the display.
3. Press the RESET key; the message “PG” will appear on the display.
4. Press the DOWN key; the message “LO” will appear on the display.
5. Press either the UP or DOWN key until your desired number (the desired degree of shaft rotation) appears on the display.
6. Press the RESET key to complete the sequence.

LOW FIRE CONTACT RELEASE (LL)

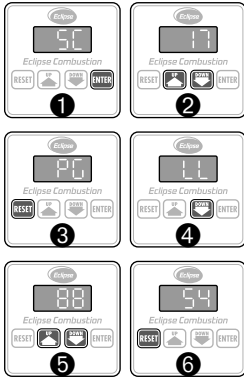

LOW FIRE CONTACT SENSE (LS)

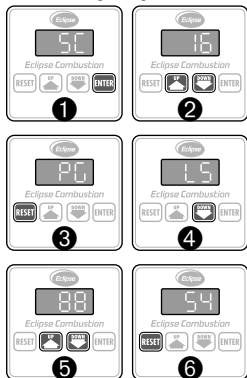

Note:

Please refer to Figure 5 on page 24 for an illustration of the next two parameters.

This description of the contact state is for the normally open mode. As the shaft travels from high to low, the LL parameter sets where the low fire contact opens back up after having closed at the LS setting. For most applications this value should be kept at zero (0). Set LF to 0 first if you need to set LL to 0. Do not view LL through code 17 after it is set. Instead, press the RESET key twice to see all parameters (See p. 28, "Examine Setpoints.")

1. Press the ENTER key; the message "SC" will appear on the display.
2. Press either the UP or DOWN key until the number "17" appears on the display.
3. Press the RESET key; the message "PG" will appear on the display.
4. Press the DOWN key; the message "LL" will appear on the display.
5. Press either the UP or DOWN key until your desired number (the desired degree of shaft rotation) appears on the display; this number must be of lesser value than the desired low fire contact sense (LS) number.
6. Press the RESET key to complete the sequence.

This description of the contact state is for the normally open mode. As the shaft travels from high to low, the LS parameter sets where the low fire contact closes. For most applications this value should be kept at least five degrees above LF or LO, whichever is higher.

1. Press the ENTER key; the message "SC" will appear on the display.
2. Press either the UP or DOWN key until the number "16" appears on the display.
3. Press the RESET key; the message "PG" will appear on the display. (Continued on page 25)

Figure 5 Auxiliary Contact Positions in Relation to Shaft Rotation



Note:

In the following examples:

- 1) 0° and 90° represent the actuator shaft's range of travel rather than the shaft's alignment (therefore, 0° does not equal vertical and 90° does not equal horizontal).
- 2) The operating mode is normally open, but the values LL, LS, HS and HH have been changed from the default setpoints shown on page 29. The set values are: LL=10, LS=20, HS=75 and HH=85

Low Auxiliary Contact (P2-5 & 6)

Angular Diagram

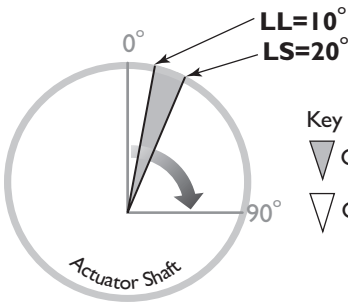

For the settings of note 2, the low contact is closed when the shaft is between 10 and 20 degrees.

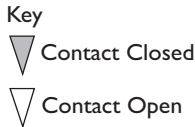

Linear Diagram

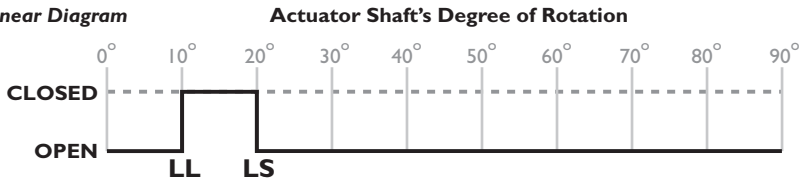

High Auxiliary Contact (P2-3 & 4)

Angular Diagram

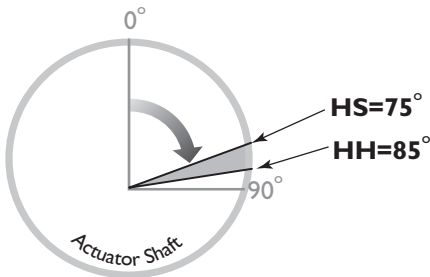

For the settings of note 2, the high contact is closed when the shaft is between 75 and 85 degrees.

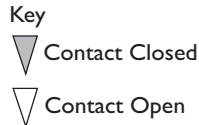

Linear Diagram

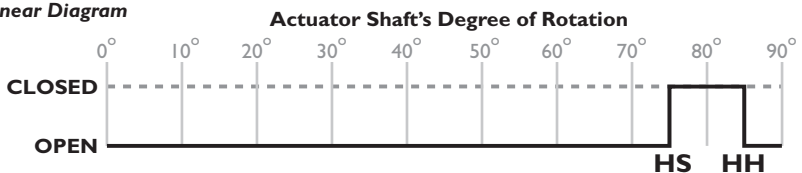



HIGH FIRE CONTACT SENSE (HS)

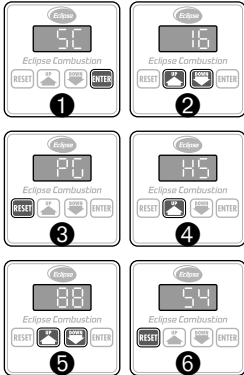

4. Press the DOWN key; the message “LS” will appear on the display.
5. Press either the UP or DOWN key until your desired number (the desired degree of shaft rotation) appears on the display; this number must be of greater value than the desired low fire contact release (LL) number.
6. Press the RESET key to complete the sequence.

 **Note:**

Please refer to Figure 5 on page 24 for an illustration of the next two parameters.

This description of the contact state is for the normally open mode. As the shaft travels from low to high, the HS parameter sets where the high fire contact closes. For most applications this value should be kept at least 5 degrees below HF.

1. Press the ENTER key; the message “SC” will appear on the display.
2. Press either the UP or DOWN key until the number “16” appears on the display.
3. Press the RESET key; the message “PG” will appear on the display.
4. Press the UP key; the message “HS” will appear on the display.
5. Press either the UP or DOWN key until your desired number (the desired degree of shaft rotation) appears on the display; this number must be of lesser value than the desired high fire contact release (HH) number.
6. Press the RESET key to complete the sequence.

HIGH FIRE CONTACT RELEASE (HH)

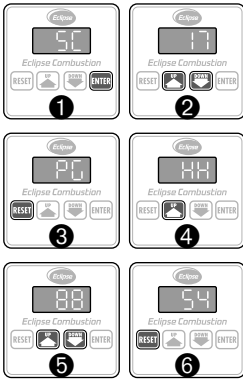

This description of the contact state is for the normally open mode. As the shaft travels from low to high, the HH parameter sets where the high fire contact opens back up after having closed at the HS setting. For most applications this value should be kept at 90. Set HF to 90 first if you need to set HH to 90. Do not view HH through code 17 after it is set. Instead, press the RESET key twice to see all parameters.

1. Press the ENTER key; the message “SC” will appear on the display.
2. Press either the UP or DOWN key until the number “17” appears on the display.
3. Press the RESET key; the message “PG” will appear on the display.
4. Press the UP key; the message “HH” will appear on the display.
5. Press either the UP or DOWN key until your desired number (the desired degree of shaft rotation) appears on the display; this number must be of greater value than the desired high fire contact sense (HS) number.
6. Press the RESET key to complete the sequence.

MANUAL POSITION SELECT

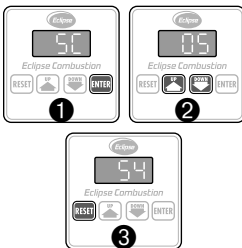

This parameter puts the actuator in the manual positioning mode. It allows the operator to manually position the shaft anywhere between low and high fire stop settings with the UP and DOWN keys:

1. Press the ENTER key; the message “SC” will appear on the display.
2. Press either the UP or DOWN key until the number “05” appears on the display.
3. Press the RESET key to complete the sequence.

AUTOMATIC SIGNAL INPUT SELECT

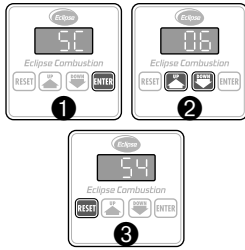

AUXILIARY CONTACT SELECT— NORMALLY CLOSED

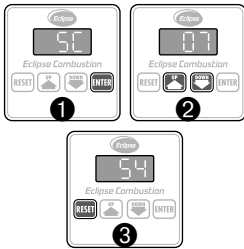

AUXILIARY CONTACT SELECT— NORMALLY OPEN

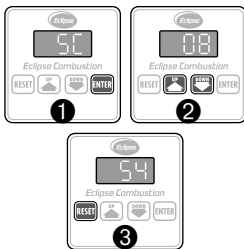

This parameter takes the actuator out of the manual positioning mode. The shaft automatically positions at a point between low and high fires according to 4-20mA, 0-10Vdc or LF/HF inputs on the connector:

1. Press the ENTER key; the message “SC” will appear on the display.
2. Press either the UP or DOWN key until the number “06” appears on the display.
3. Press the RESET key to complete the sequence.

This parameter allows the operator to change the auxiliary contact from the normally open (NO) default to normally closed (NC):

1. Press the ENTER key; the message “SC” will appear on the display.
2. Press either the UP or DOWN key until the number “07” appears on the display.
3. Press the RESET key to complete the sequence.

This parameter allows the operator to return the auxiliary contact’s default setting to normally open (NO) if ever changed:

1. Press the ENTER key; the message “SC” will appear on the display.
2. Press either the UP or DOWN key until the number “08” appears on the display.
3. Press the RESET key to complete the sequence.



Note:

The next two parameters describe shaft rotation when facing the keypad.



Warning:

Disconnect shaft coupling before changing. The shaft will reposition as such that 0 becomes 90 degrees.

CLOCKWISE ROTATION SELECT

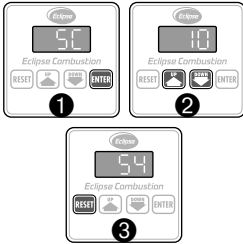

COUNTERCLOCKWISE ROTATION SELECT

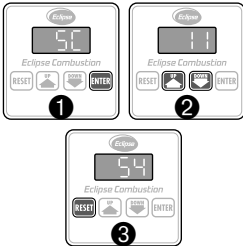

EXAMINE SETPOINTS

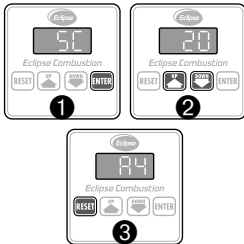

This parameter allows the shaft to travel clockwise when the input signal increases:

1. Press the ENTER key; the message “SC” will appear on the display.
2. Press either the UP or DOWN key until the number “10” appears on the display.
3. Press the RESET key to complete the sequence.

This parameter allows the shaft to travel counterclockwise when the input signal increases:

1. Press the ENTER key; the message “SC” will appear on the display.
2. Press either the UP or DOWN key until the number “11” appears on the display.
3. Press the RESET key to complete the sequence.

Pushing the RESET key twice allows the various setpoints to be examined. Once activated, the display will indicate a two-letter parameter code followed by its value in the following sequence:

- a. software version;
- b. low fire stop position (LF);
- c. high fire stop position (HF);
- d. contact signal loss position (LO);
- e. low fire contact release position (LL);
- f. low fire contact sense position (LS);
- g. high fire contact sense position (HS);
- h. high fire contact release position (HH);
- i. manual (C5) or automatic (C6);
- j. aux. contact mode N.O. (C8) or N.C. (C7);
- k. rotation CW (CO) or CCW (C1)

The display will show each function's setpoint for two seconds before scrolling to the next one.

DEFAULT SETPOINTS

This parameter resets the actuator to the default setpoints. The default setpoints are as follows:

- Automatic input signal;
- Normally open (NO) contact;
- Clockwise (CW) rotation;
- 0° for LO, or control signal loss position;
- 0° for LF, or low fire contact stop;
- 0° for LL, or low fire contact release;
- 5° for LS, or low fire contact sense;
- 85° for HS, or high fire contact sense;
- 90° for HH, or high fire contact release, and
- 90° for HF, or high fire contact stop.

To reset the parameters to the default setting:

1. Press the ENTER key; the message “SC” will appear on the display.
2. Press either the UP or DOWN key until the number “20” appears on the display.
3. Press the RESET key to complete the sequence.

STALLED MOTOR



If the motor is stalled for more than 30 seconds, the motor will stop and the display will indicate the percentage (%) sign.

Normal display and operation will resume automatically when the actuator is commanded to move in the opposite direction from the stall. To reverse direction while in the automatic mode, change either the analog input signal, apply a digital low fire or high fire input, or change to the manual mode. In some cases it may be necessary to disconnect the mechanical coupling to the valve.



Specifications

4

PARAMETER	DESCRIPTION
Power Supply	120VAC (+10%, -15%), 50/60 Hz or 230VAC (+10%, -15%), 50/60 Hz Internal power consumption: 5VA
Operating Temperature	-20 to +60 °C (0 to 140 °F)
Storage Temperature	-25 to +65 °C (-10 to 150 °F)
Humidity	5-95% RH noncondensing
Environment	NEMA 4
Inputs, Analog	4-20mA @ 250Ω impedance; 0-10Vdc @ 200KΩ Impedance
Inputs, Digital (Isolated contacts)	Force to high position; force to low position; disable setting codes
Shaft Rotation	Adjustable, 0 to 90° maximum.
Minimum Step	1°
Shaft Rotation Direction	Selectable: clockwise or counterclockwise
Keypad Orientation	Four positions
Display Accuracy	± 1.5°
Position Indicator	9/16" high LED, 0 to 90°
Speed	13 seconds nominal for 90° @ 60Hz
Torque (Stall Protected)	2.3 N-m (20 lb-in) 3.9 N-m (35 lb-in) @ stall
Auxiliary Contact Ratings	
Resistive Load:	8A
Inductive Load:	2A
Wiring Connectors	Flexible cord connector: 5.8 to 10 mm (0.231 to 0.394 in.) OD cable 3/8 in. liquid tight conduit 1/2 in. Female NPT adapter
Terminal Connections	0.5 - 1.5 mm ² (22 - 16 AWG)
Shipping Weight	1.1 kg (2.5 lb.)

Dimensions

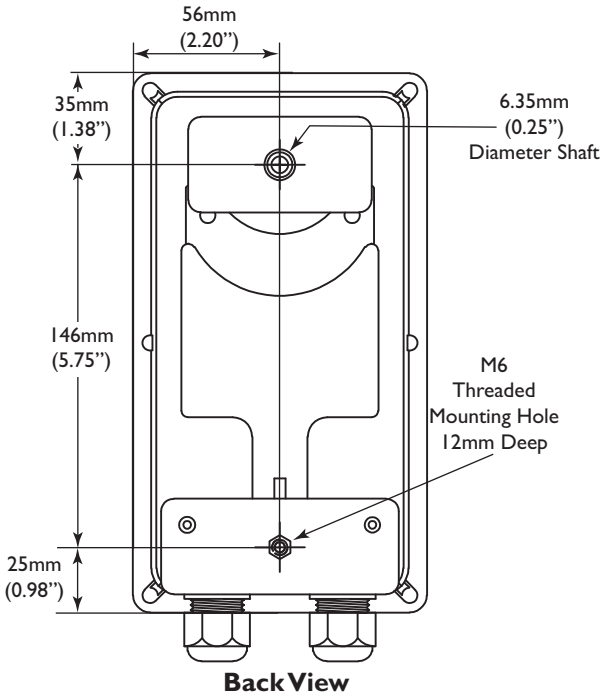
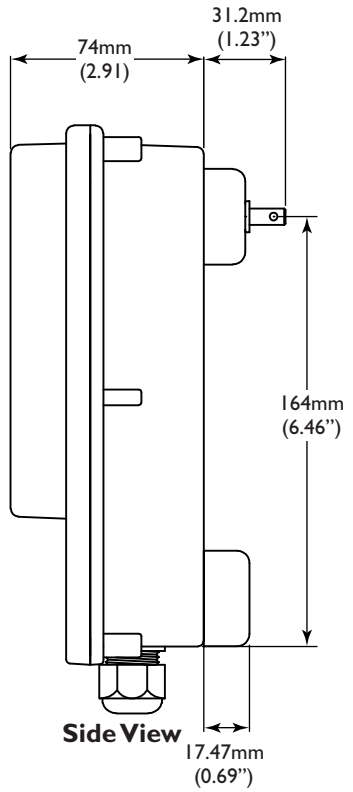
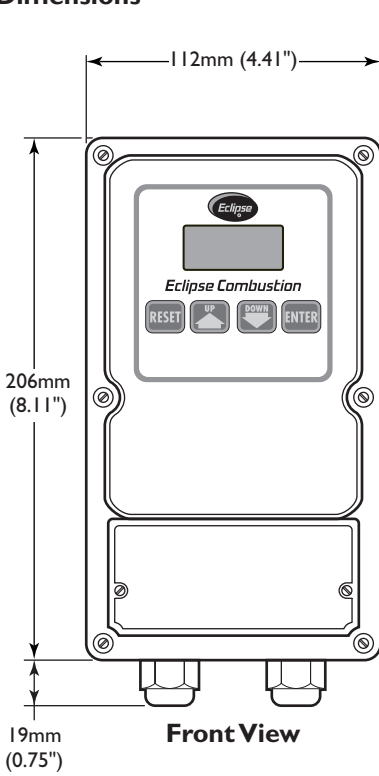

Dimensions (continued)

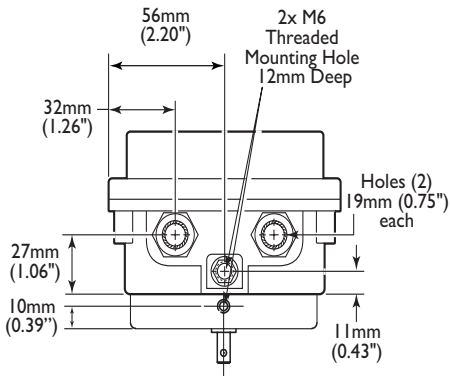

Bottom End View

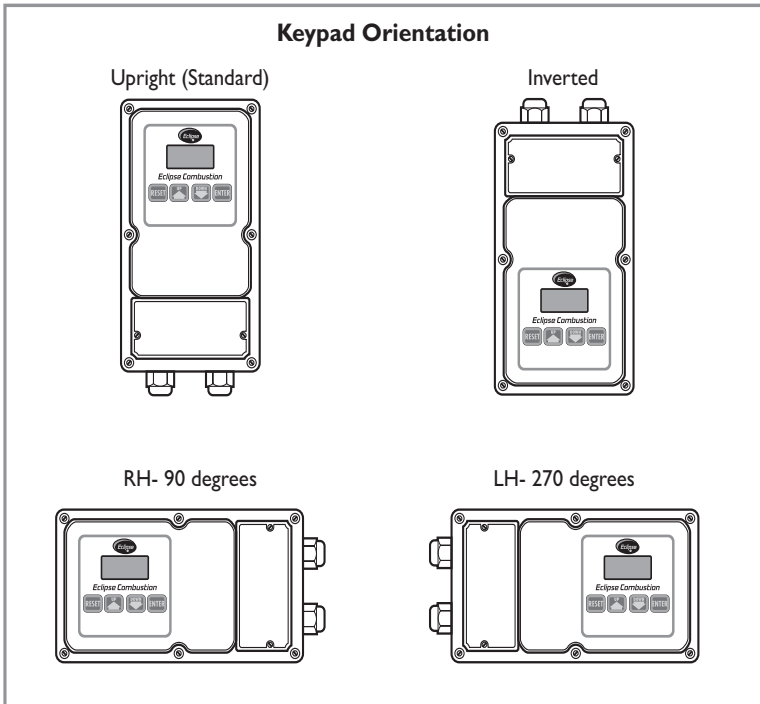
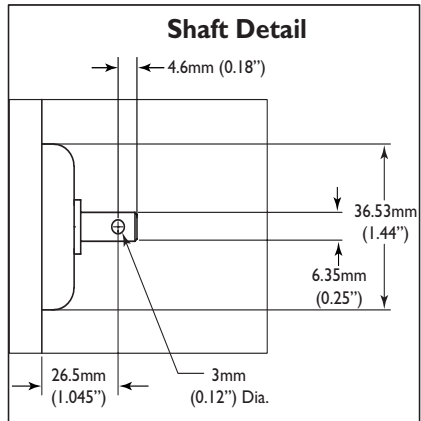

Maintenance & Troubleshooting

5

INTRODUCTION

This section is divided into two parts:

- The first part describes maintenance procedures.
- The second part describes troubleshooting procedures.

MAINTENANCE

Preventative maintenance is the key to a reliable, safe and efficient actuator. The core of any preventative maintenance program is a list of periodic tasks.



Note:

The monthly and yearly lists are for average intervals. If your environment is dirty, then the intervals may be shorter.

Monthly Checklist

1. Inspect the actuator for physical damage to the housing or display.
2. Inspect the coupling for loose connections.
3. Observe the shaft while moving for smooth operation.

Yearly Checklist

1. Inspect the actuator for physical damage to the housing or display.
2. Inspect the coupling for loose connections.
3. Confirm the parameters settings are identical to those originally selected.
4. Drive the actuator to its full clockwise and counterclockwise positions and observe the shaft while moving for smooth operation.

TROUBLESHOOTING

PROBLEM	POSSIBLE CAUSE	SOLUTION
No display messages.	<ul style="list-style-type: none"> No voltage at P2-1 & P2-2. 	Check power supply.
Actuator will not move with signal.	<ul style="list-style-type: none"> Stalled motor; "Oo" message on display. 	Correct the mechanical problem; see "Stalled Motor" on page 29.
	<ul style="list-style-type: none"> Actuator is in manual mode. 	Deselect manual mode; see "Automatic Signal Input Select" on page 27.
	<ul style="list-style-type: none"> Actuator at low or high fire stop. 	Refer to "Actuator Mounting" on page 11; check parameter settings for low and high fires.
	<ul style="list-style-type: none"> Signal reversed or no signal connection. 	Check wiring and refer to Figure 3 on page 18.
Actuator will not move with keypad.	<ul style="list-style-type: none"> Manual mode not selected 	Select manual mode; see "Manual Position Select" on page 26.
	<ul style="list-style-type: none"> Defective keypad 	Call your Eclipse sales rep.
	<ul style="list-style-type: none"> External connection to high fire input (PI-5 to PI-1) or low fire input (PI-4 to PI-1). 	Check wiring and remove external connection.
	<ul style="list-style-type: none"> Stalled motor; "Oo" message on display. 	Correct the mechanical problem; see "Stalled Motor" on page 29.
Displays "LC"	<ul style="list-style-type: none"> Setting mode disabled. 	See "Disable Settings Wiring" on page 17.

Appendix

Table 1 Actuator Parameter Configuration Record

Low Fire Stop	LF	15 Down	0°	
High Fire Stop	HF	15 Up	90°	
Control Signal Loss	LO	12 Down	0°	
Low Fire Contact Release	LL	17 Down	0°	
Low Fire Contact Sense	LS	16 Down	5°	
High Fire Contact Sense	HS	16 Up	85°	
High Fire Contact Release	HH	17 Up	90°	
Manual Position Select	[C5]	05	No	
Signal Input Select	[C6]	06	Yes	
Auxiliary Contact Select— Normally Closed (NC)	[C7]	07	No	
Auxiliary Contact Select— Normally Open (NO)	[C8]	08	Yes	
Clockwise (CW) Rotation Select	[C0]	10	Yes	
Counterclockwise (CCW) Rotation Select	[C1]	11	No	
Examine Setpoints		Reset twice	—	
Default Setpoints		20	—	

Table 2 Model Number Configuration

